

Zebra

Pedestrian cross

Model: Peter Budai © 2002.
Diagrams: Peter Budai © 2002.

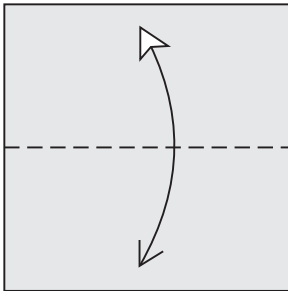
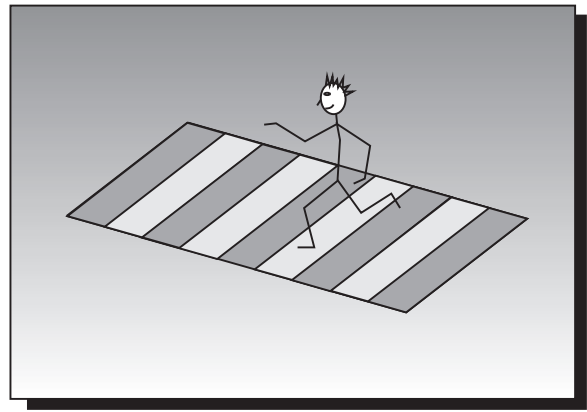

1. Oda-visszahajtás félbe.
Fold in half and unfold.

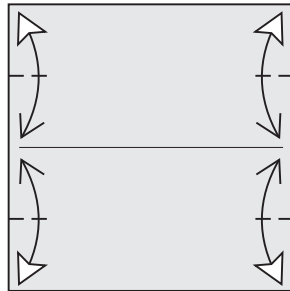

2. Távfelező jelzőhajtások.
Crease halving distances.

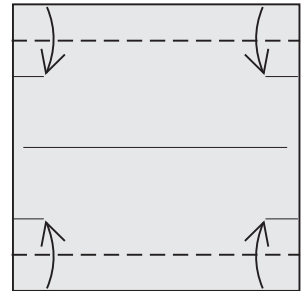

3. Behajtsunk a friss élékhez.
Fold in to the new creases.

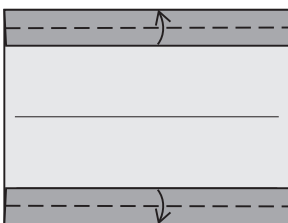

4. Kihajtsunk a szélekre.
Fold out to the edges.

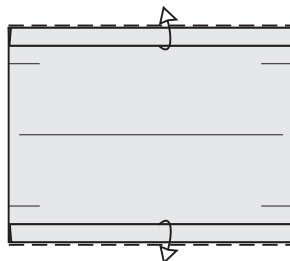

5. Visszacsináljuk a 3. lépést.
Undo step 3.

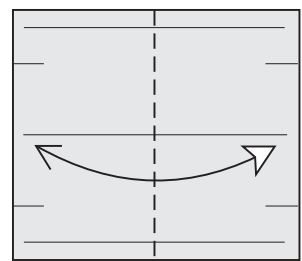

6. Oda-visszahajtás félbe.
Fold in half and unfold.

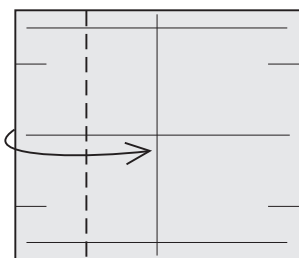

7. Balról középre hajtsunk.
Fold the left to the center.

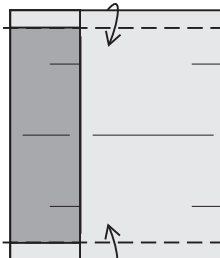

8. A széleket ismét behajtsuk.
Fold the edges in again.

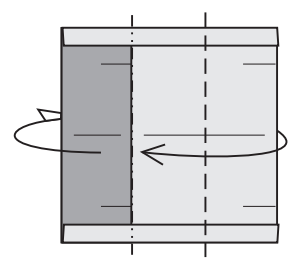

9. Háromba hajtsuk a papírt.
Fold the paper in thirds.

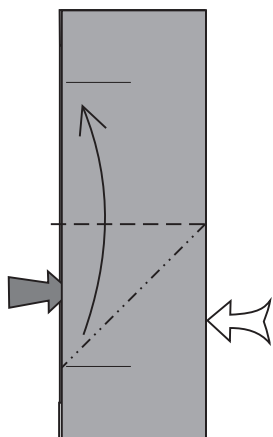

10. Nagyított kép.
Préshajtás felfelé.
*Enlarged view.
Squash-fold up.*

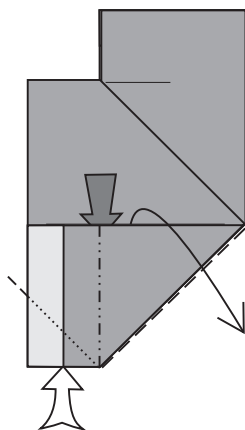

11. Forgóhajtás jobbra
lefelé.
*Swivel-fold down
to the right.*

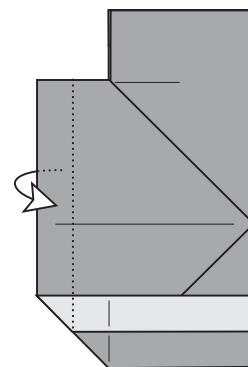

12. Előreborítunk.
Wrap to the front.

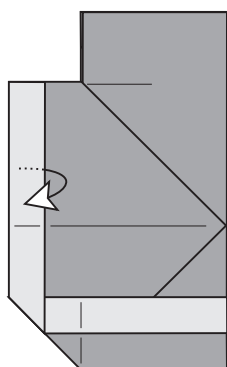

13. Előreborítunk
ismét.
*Wrap to the
front again.*

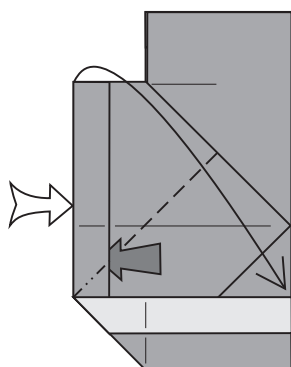

14. Váltóhajtás befelé.
Inside-reverse-fold.

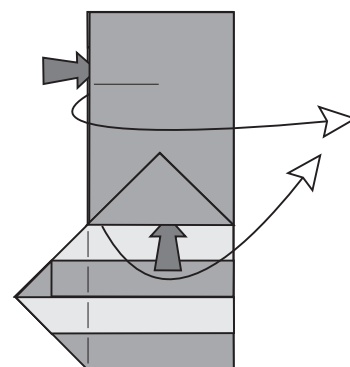

15. Felszabadítjunk a
magszorult papírt...
*Release some
trapped paper...*

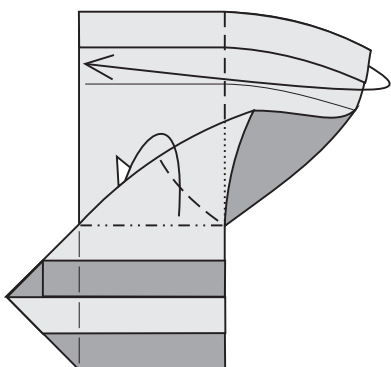

16. ...így. Forgóhajtás hátrafelé.
...like this. Swivel-fold behind.

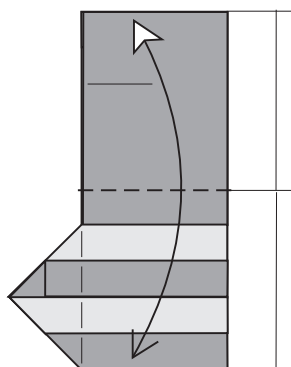

17. Oda-visszahajtás félbe.
Fold in half and unfold.

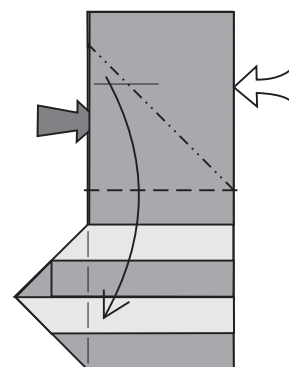

18. Préshajtás lefelé.
Squash-fold down.

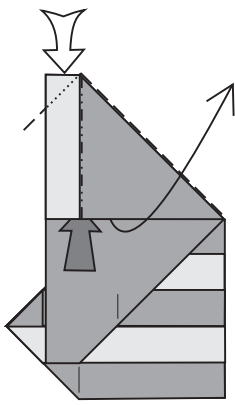

19. Forgóhajtás jobbra fel.
Swivel-fold up to the right.

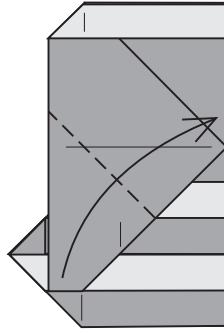

20. Felhajtjuk a fület.
Fold the flap up.

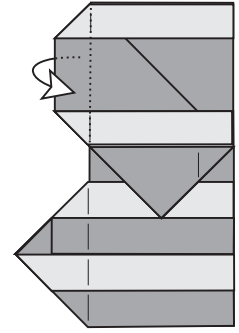

21. Előreborítunk.
Wrap to the front.

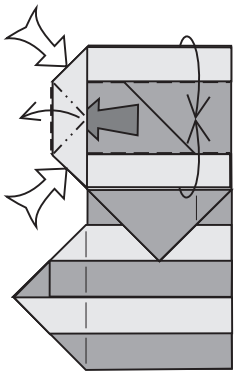

22. Sziromhajtás balra.
Petal-fold to the left.

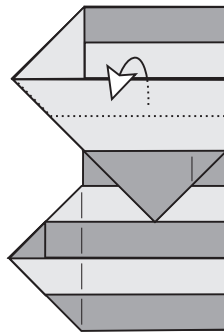

23. Előreborítunk.
Wrap to the front.

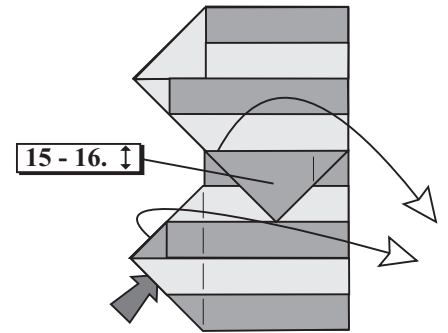

24. Ismételjük a lépéseket
15-16-ig tükörszerűen.
*Repeat steps 15-16
in mirror image.*

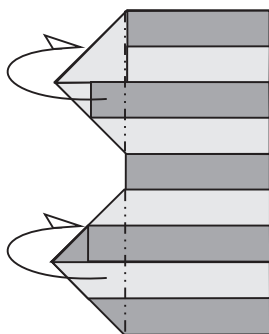

25. Hátrahajtunk a füleket
bele a zsebbe.
*Mountain-fold the flaps
into the pocket.*



26. Kész a zebra.
Figyeljünk oda a forgalomra!
*The pedestrian cross is finished.
Watch out for the traffic!*

